

MOD : CRB1-SA6

Production code : DSC1E405813DIA

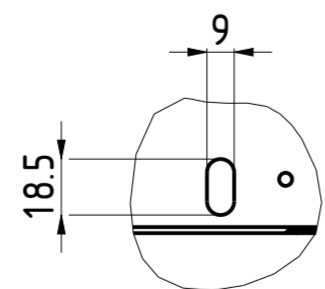
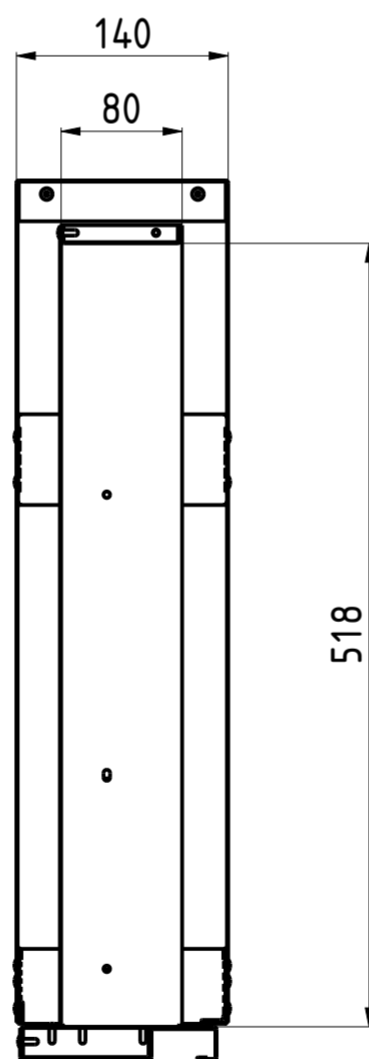
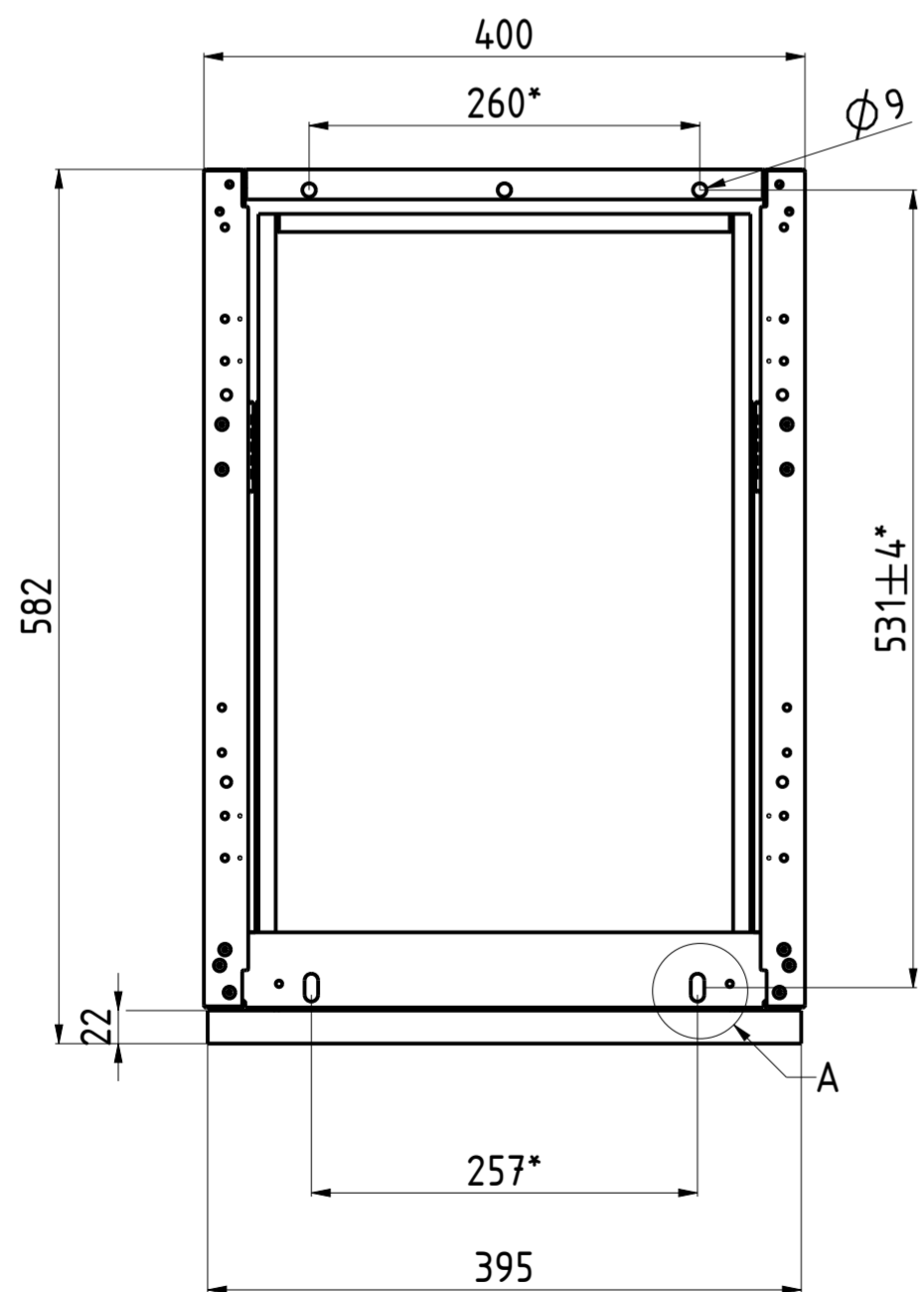
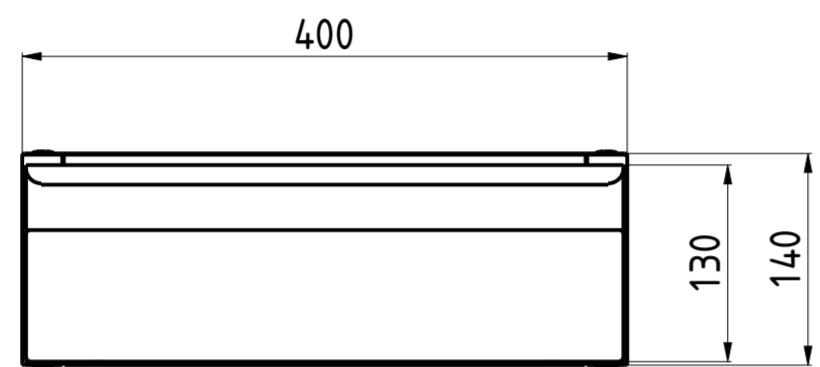
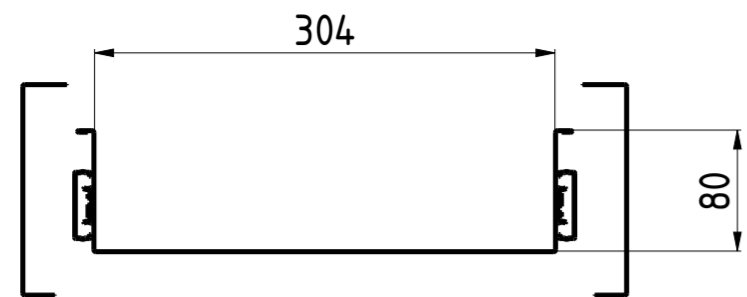

FORI FISSAGGIO
FIXING HOLES

FORI FISSAGGIO
FIXING HOLES

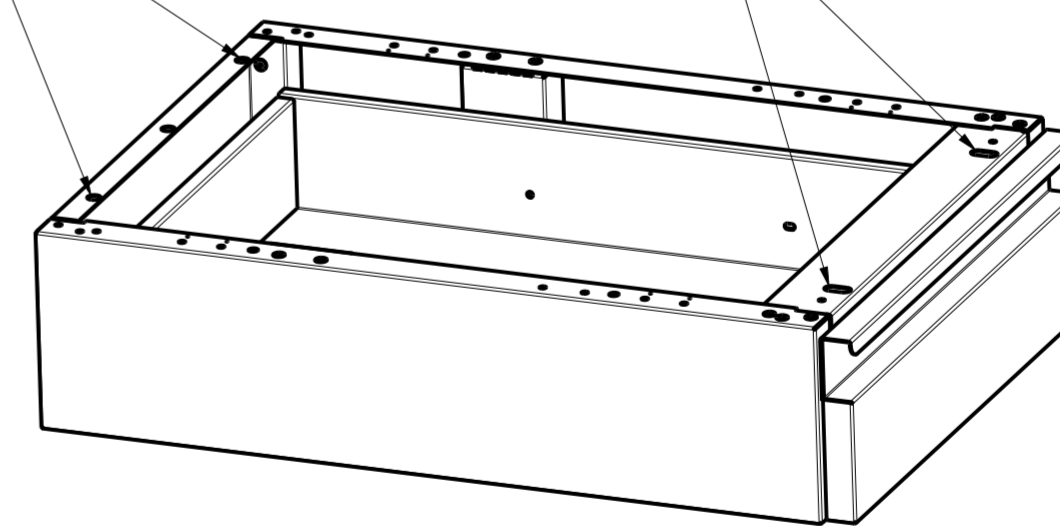

* INTERASSE FORATURA FISSAGGIO CASSETTO
* CENTER DISTANCE BETWEEN FIXING HOLES

SCHEDA TECNICA / DATA SHEET

MODELLO / MODEL :
CRB1-SA6



CASSETTO CON SUPPORTO L400 P600 H130 DIA
DRAWER WITH SUPPORT ASSEMBLY L400 P600 H130 DIA

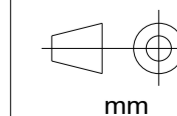

mm

FORM.A-2

QUOTE SENZA TOLLERANZA TOLLERANCE UNLESS OTHERWISE STATED

5-10	±0.15
10-18	±0.20
18-30	±0.25
30-50	±0.30
50-80	±0.35
80-120	±0.40
120-180	±0.45
180-250	±0.50
250-315	±0.55
315-400	±0.60
400-500	±0.65
>500	±0.75

ANGOLI
Angles
±0.30°

QUOTA PRIMARIA
PRIMARY DIMENSION
XX

ELABORATO CON SISTEMA CAD
DESIGNED BY CAD/STEM