

MOD : GBG1-7

Production code : NYG7-20

Oriental Cooking - Roaster & Grill

Gas - Yakitori / Skewer Grill

NYG 7-20 LS CE



Due to continuous technical development, the image shown may not represent the latest design of the unit.

DESCRIPTION

Table-top, compact lava stone gas grill with a high-performance burner of 7 kW power rate.

Made of stainless steel with a removable grill and a grease/grilling debris collection tray for ease of use and cleaning.

With the indirect grilling method, the NYG is perfect for preparing all kind of meat and vegetable skewers like Satay, Yakitori, Shaslik, Sish Kebab, Köfta etc.

OTHER AVAILABLE MODELS

- NYG 14-20 LS CE

MAIN FEATURES

- High-performance, atmospheric tubular burner with a power rate of 7 kW.
- Heat diffuser for even heat distribution.
- Piezo ignition.
- Equipped with pilot burner, safety thermocouple, gas valve, gas knob.
- Reinforced wire grill for lava stones.
- CE certified unit.

CONSTRUCTION

- Sturdy frame made of stainless steel AISI 430.
- Stainless steel top panel (1.0 mm), AISI 304 with hairline surface pattern.
- Front and side panels (1.0 mm) made of stainless steel AISI 304 with hairline surface pattern.
- Back panel (1.0 mm) made of stainless steel AISI 304 with hairline surface pattern.
- Height adjustable levelling legs.
- Types of installations: table-top.
- Frame, top and panels, all made of high-grade stainless steel.

INCLUDED ACCESSORIES

- Lava stones.

OPTIONAL ACCESSORIES

- Stainless steel BBQ grill adapter.

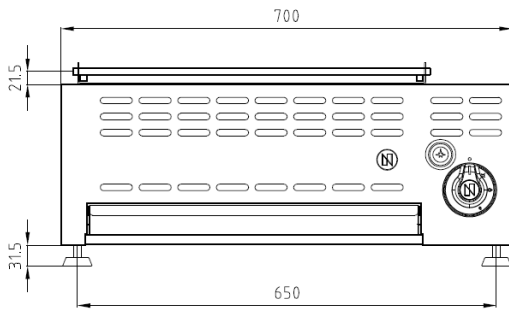
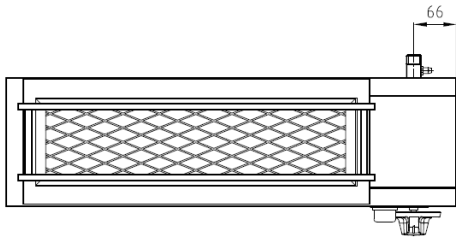
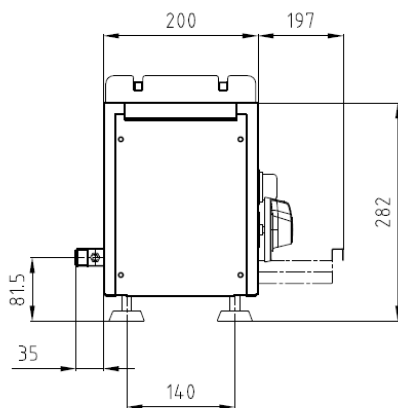
FRONT

TOP

SIDE

TECHNICAL DATA
External Dimensions

Width : 700 mm
 Depth : 200 mm
 Height : 282 mm

Cooking Surface

Cooking zones : 500 x 136 mm

Gas Power Rating

Heat input total : LPG/LNG 7 kW
 No. of burners : 1
 Control type : High-low power control
 Gas type options : LPG G30, G31
 LNG G20, G25

Connections

Gas : DN15 (1/2")
 Water : N/A
 Drain : N/A

Heat & Steam Emissions

Direct heat emission : LPG/LNG 2.45 kW
 Latent heat emission : LPG/LNG 2.8 kW
 Steam emission : LPG/LNG 4.12 kg/h

PACKAGING DATA

Width : 730 mm
 Depth : 230 mm
 Height : 402 mm
 Volume : 0.07 m³

WEIGHT

Net Weight : 26 kg
 Gross Weight : 37 kg

*Overall dimension in mm