

05/2022

# **Mod: G22/F23CFSA4-AC**

**Production code: 393343**

**Modular Cooking Range Line  
ECO 90 One Well Programmable  
Gas Fryer 23 liter with Electronic  
Control, Pump and Lifter**

ITEM # \_\_\_\_\_

MODEL # \_\_\_\_\_

NAME # \_\_\_\_\_

SIS # \_\_\_\_\_

AIA # \_\_\_\_\_



**393343 (N9KKLBAMCG)**

23-lt gas fryer with 1 "V" shaped well (external heating elements), electronic control, programmable, oil recirculation pump, 2 half size baskets, automatic lifting system for baskets, automatic cooking mode, predisposed for advanced filtering system

**Short Form Specification**

Item No. \_\_\_\_\_

High efficiency 25 kW burners in stainless steel. Suitable for natural gas or LPG. Deep drawn V-Shaped well and equipped with programmable electronic control panel. Automatic basket lifting system and automatic cooking mode. Unit predisposed for advanced filtering system to remove the smallest food residuals and extend the oil life. Oil drains through a tap into a container positioned under the well. Melting function to safely heat-up solid shortening used to fry products. Height adjustable feet in stainless steel. Exterior panels in stainless steel. Worktop in 20/10, stainless steel. Right-angled side edges eliminate gaps and possible dirt traps between units.

**Main Features**

- Deep drawn V-Shaped well.
- Built-in smart electronic control system to monitor the temperature during frying to guarantee the safety of the process.
- Overheat protection thermostat as standard on all units.
- Integrated oil filtering system with a pump for oil circulation.
- The unit is predisposed for ADVANCED FILTERING SYSTEM with paper filters to remove the smallest food residuals and extend the oil life.
- Unit to feature automatic basket lifting system and AUTOMATIC COOKING mode.
- Unit able to memorize 5 programs (temperature and time) and 5 extra programs can be customized using the automatic cooking mode allowing to adjust the cooking time automatically according to the load.
- All major compartments located in front of unit for ease of maintenance.
- Unit to be equipped with electronic control panel.
- IPX5 water resistance certification.
- Supplied as standard with 2 half size baskets and 1 right side door for cupboard.
- The special design of the control panel offers a better guarantee against oil infiltration.
- Thermostatic regulation of oil temperature up to a maximum of 190 °C.
- Optional portable oil quality monitoring tool (code 9B8081) for efficient oil management.

**Construction**

- All exterior panels in Stainless Steel with Scotch Brite finishing.
- Model has right-angled side edges to allow flush fitting joints between units, eliminating gaps and possible dirt traps.
- Interior of well with rounded corners for ease of cleaning.
- Unit is 900mm deep to give a larger working surface area.
- Unit delivered with four 50 mm legs in stainless steel as standard.

**Included Accessories**

- 1 of OIL FILTER S/S FOR 23 LT FRYERS PNC 200086
- 1 of Door for open base cupboard PNC 206350
- 1 of 2 half size baskets for 18/23 lt fryers PNC 927223

**Optional Accessories**

- KIT FOR ADVANCED FILTRATION SYSTEM FOR 23LT FRYER PNC 200084
- PACK OF 100 PAPER FILTER FOR ADVANCED FILTRATION SYSTEM FOR 23LT FRYER PNC 200085
- OIL FILTER S/S FOR 23 LT FRYERS PNC 200086
- KIT23L FRYER OIL PUMP DRAIN EXTENSION PNC 200087
- Junction sealing kit PNC 206086
- Draught diverter, 120 mm diameter PNC 206126

APPROVAL: \_\_\_\_\_

**Modular Cooking Range Line  
ECO 90 One Well Programmable Gas Fryer 23 liter with  
Electronic Control, Pump and Lifter**

**Modular Cooking Range Line  
ECO 90 One Well Programmable Gas  
Fryer 23 liter with Electronic Control,  
Pump and Lifter**

- Matching ring for flue condenser, 120 mm diameter PNC 206127
- Kit 4 wheels - 2 swivelling with brake - it is mandatory to install base support and wheels PNC 206135
- Flanged feet kit PNC 206136
- Pair of side kicking strips (not for refr-freezer base) PNC 206180
- Frontal kicking strip for 23lt fryers in two parts PNC 206203
- Extension pipe for oil drainage for fryers PNC 206209
- Chimney upstand, 400mm PNC 206303
- Flue condenser for 1/2 module, 120 mm diameter PNC 206310
- Base support for feet or wheels (lateral) for 23lt fryers, pastacookers and refrigerated bases PNC 206372
- SEDIMENT TRAY FOR 23LT FRYER PNC 921023
- 2 half baskets for 18/23lt fryers with front hook PNC 927200
- 1 full basket for 18/23lt fryers with front hook PNC 927201
- 2 half size baskets for 18/23 lt fryers PNC 927223
- Pressure regulator for gas units PNC 927225
- 1 full size basket for 18/23 lt fryers PNC 927226
- Unclogging rod for 23lt fryers drainage pipe PNC 927227
- Deflector for floured products for 23lt fryers PNC 960645



## Modular Cooking Range Line ECO 90 One Well Programmable Gas Fryer 23 liter with Electronic Control, Pump and Lifter

### Front

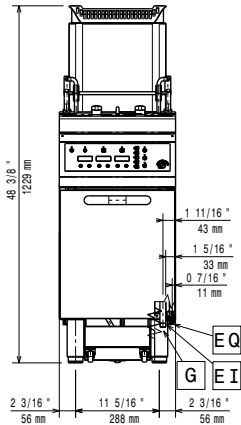

### Side

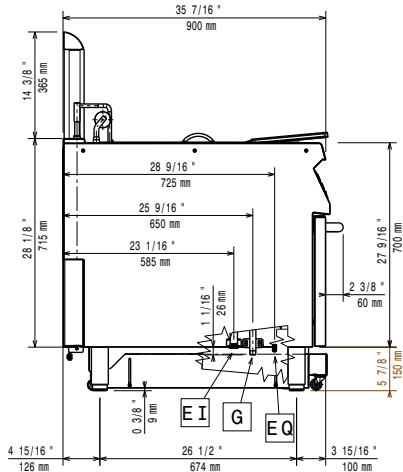

- EI = Electrical inlet (power)
- EQ = Equipotential screw
- G = Gas connection

### Top

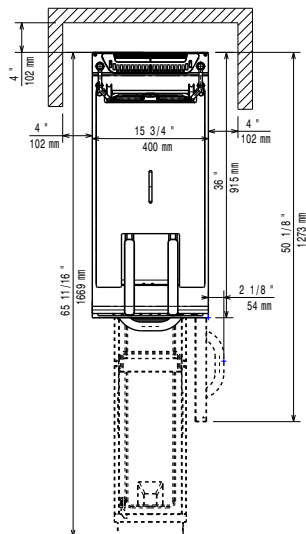

### Gas

Gas Power:	393343 (N9KKLBAMCG)	26 kW
Gas Type Option:		LPG; Natural Gas
Gas Inlet:		1/2"

### Key Information:

Usable well dimensions (width):	340 mm
Usable well dimensions (height):	575 mm
Usable well dimensions (depth):	400 mm
Well capacity:	21 Lt MIN; 23 Lt MAX
Thermostat Range:	110 °C MIN; 190 °C MAX
Net weight:	96 kg
Shipping weight:	108 kg
Shipping height:	1480 mm
Shipping width:	460 mm
Shipping depth:	1020 mm
Shipping volume:	0.69 m <sup>3</sup>
Certification group:	GF91L23

If appliance is set up or next to or against temperature sensitive furniture or similar, a safety gap of approximately 150 mm should be maintained or some form of heat insulation fitted.



**Modular Cooking Range Line  
ECO 90 One Well Programmable Gas Fryer 23 liter with Electronic  
Control, Pump and Lifter**  
The company reserves the right to make modifications to the products  
without prior notice. All information correct at time of printing.