

04/2015

# Mod: **GMB/100I**

**Production code: P432 31340 (PTBC IG100)**



**Diamond**  
catering equipment

*These are automatic tilting cooking pots, with lateral support uprights. These models are designed for cooking solid foods that are transferred by tipping of the container. On request, they are fitted with a 2" spout for emptying the liquids involved in the cooking process.*

## TECHNICAL FEATURES

### Cooking tank

- Cooking tank with bottom in AISI 316 polished stainless steel and walls in AISI 304 stainless steel

### Jacket (indirect heated version)

- Jacket with bottom and walls in AISI 304 stainless steel

### Lid

- Balanced lid in AISI 304 stainless steel with heat resistant handle

### SUPPORT FRAME AND PANELS

- Stainless steel frame
- Thermal insulation assured by high density ceramic fibre 64/128
- Panels in AISI 304 stainless steel, fine satin finish

### Tilting of the container

- Automatic tilting with hydraulic drive
- Electric supply: 400V 3N 50Hz

### Heating system

#### *Direct Gas versions*

- Heating by means of AISI 304 stainless steel high efficiency tube burners
- Ignition by means of manual piezo-electric lighter and pilot flame
- Valve-controlled safety tap with thermocouple
- Safety thermostat
- Venting grid
- Set of jets for different types of gas



#### *Indirect Gas versions - with Jacket*

- Heating by means of AISI 304 stainless steel high efficiency tube burners
- Ignition by means of manual piezo-electric lighter and pilot flame
- Valve-controlled safety tap with thermocouple
- Venting grid
- Set of jets for different types of gas
- Jacket water level control taps max/min with the option of automatic filling
- Jacket pressure control by means of spring-loaded safety relief valve calibrated at 0,5 bar, vacuum valve and pressure gauge

#### *Indirect Electric versions - with Jacket*

- Heating by means of INCOLOY heating elements with adjustable power regulator
- Safety thermostat to prevent overheating and keeps the equipment from operating without water
- Jacket water level control taps max/min with the option of automatic filling
- Jacket pressure control by working pressure switch and spring-loaded safety relief valve calibrated at 0,45 bar, vacuum valve and pressure gauge
- Standard power supply 400V 3N 50Hz

#### *Indirect Steam versions - with Jacket*

- Heating by means of steam (from user's plant line) with a throttle valve allowing a gradual steam inlet
- Jacket pressure control by means of spring-loaded safety relief valve calibrated at 0,45 bar, vacuum valve and pressure gauge

PTBC	V	IE	GD	IG
Automatic tilting	●	●	●	●
Jacket safety assembly	●	●	-	●
Water tap	●	●	●	●
Draining tap 2" conical size	*	*	*	*
Draining tap 2" AISI 316	*	*	*	*
Drain spout filter	*	*	*	*
Valve-controlled safety tap with thermocouple	-	-	●	●
Safety thermostat	-	●	*	●
Pressure switch	-	●	-	*
Electronic water filling in jacket with probe	-	*	-	*
Electronic temperature control of cooking tank with display	*	*	*	*
Electronic temperature indicator of cooking tank with display	*	*	*	*
Electric cooking time control with display and buzzer	*	*	*	*
HACCP parameters acquisition with display and RS485 output	*	*	*	*
HACCP parameters acquisition with register + printer in paper roll (box for wall)	*	*	*	*
HACCP parameters acquisition software for PC	*	*	*	*
Manual jacket air venting	●	●	-	●
Automatic jacket air venting	*	*	-	*
Colander basket	*	*	*	*

- standard
- \* optional
- no

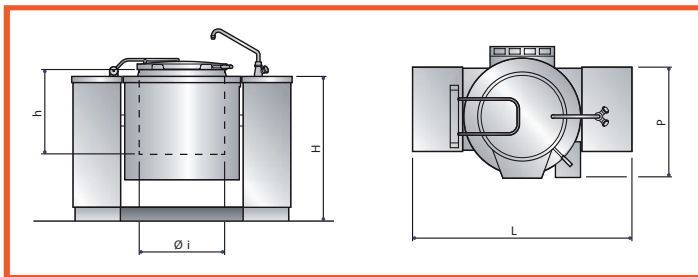

MODEL	Capacity liter	Pan Dimensions L x P x H mm	Tank Dimensions Ø i x H mm	Power (kW)		Consumption			
				Gas	Electric	L. P. G. kg/h	Nat. Gas H m³/h	Nat. Gas L m³/h	Steam kg/h
PTBC V100	100	1600x850x1050	Ø600x420	-	0,2	-	-	-	60
PTBC V150	150	1600x850x1050	Ø600x540	-	0,2	-	-	-	65
PTBC V200	200	1750x1000x1050	Ø760x500	-	0,5	-	-	-	85
PTBC V300	300	1950x1200x1300	Ø960x500	-	0,5	-	-	-	100
PTBC V500	500	2050x1300x1300	Ø1060x600	-	0,5	-	-	-	115
PTBC IE100	100	1600x850x1050	Ø600x420	-	12,2	-	-	-	-
PTBC IE150	150	1600x850x1050	Ø600x540	-	16,2	-	-	-	-
PTBC IE200	200	1750x1000x1050	Ø760x500	-	24,5	-	-	-	-
PTBC IE300	300	1950x1200x1300	Ø960x500	-	36,5	-	-	-	-
PTBC IE500	500	2050x1300x1300	Ø1060x600	-	48,5	-	-	-	-
PTBC GD100	100	1600x850x1050	Ø600x420	24	0,2	1,86	2,48	2,46	-
PTBC GD150	150	1600x850x1050	Ø600x540	24	0,2	1,86	2,48	2,46	-
PTBC GD200	200	1750x1000x1050	Ø760x500	39	0,5	3,47	4,66	5,41	-
PTBC GD300	300	1950x1200x1300	Ø960x500	39	0,5	3,47	4,66	5,41	-
PTBC GD500	500	2050x1300x1300	Ø1060x600	55	0,5	4,62	6,21	7,21	-
PTBC IG100	100	1600x850x1050	Ø600x420	24	0,2	1,74	2,74	2,3	-
PTBC IG150	150	1600x850x1050	Ø600x540	24	0,2	1,74	2,74	2,46	-
PTBC IG200	200	1750x1000x1050	Ø760x500	39	0,5	3,47	4,66	5,41	-
PTBC IG300	300	1950x1200x1300	Ø960x500	48	0,5	3,47	4,66	5,41	-
PTBC IG500	500	2050x1300x1300	Ø1060x600	55	0,5	4,62	6,21	7,21	-

- V: steam
- IE: indirect el.
- GD: direct gas
- IG: indirect gas

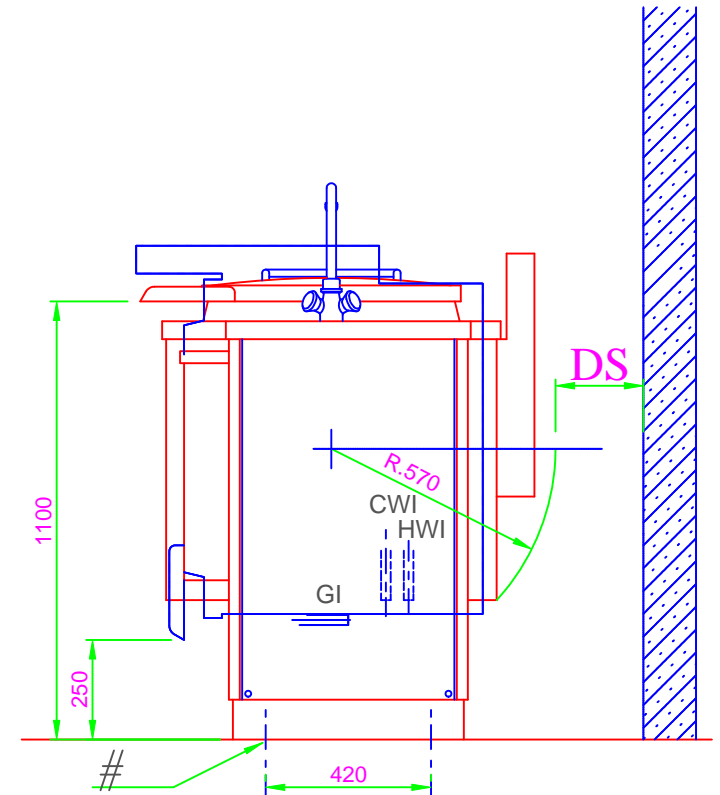
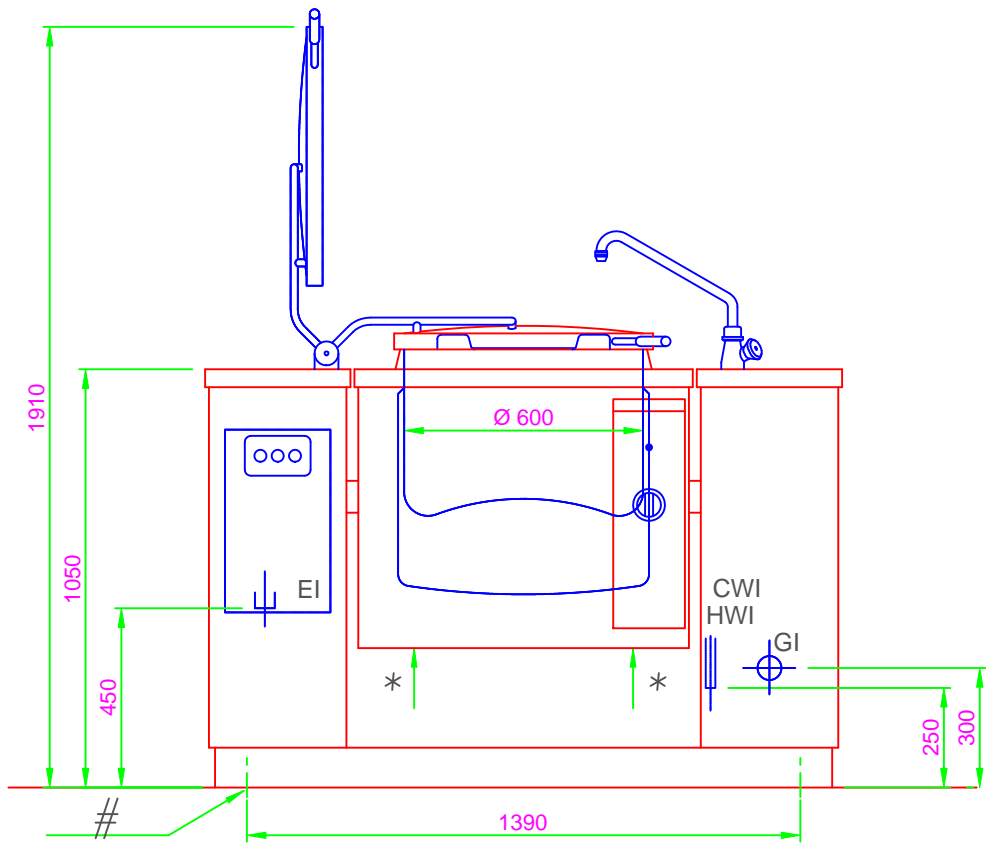

\* - LINEA DI SOLLEVAMENTO CON CARRELLO  
LIGNE DE LEVAGE AVEC CHARIOT ELEVATEUR  
TROLLEY LIFTING LINE

# - N° 4 VITI M12  
N° 4 VIS M12  
NR. 4 M12 SCREWS

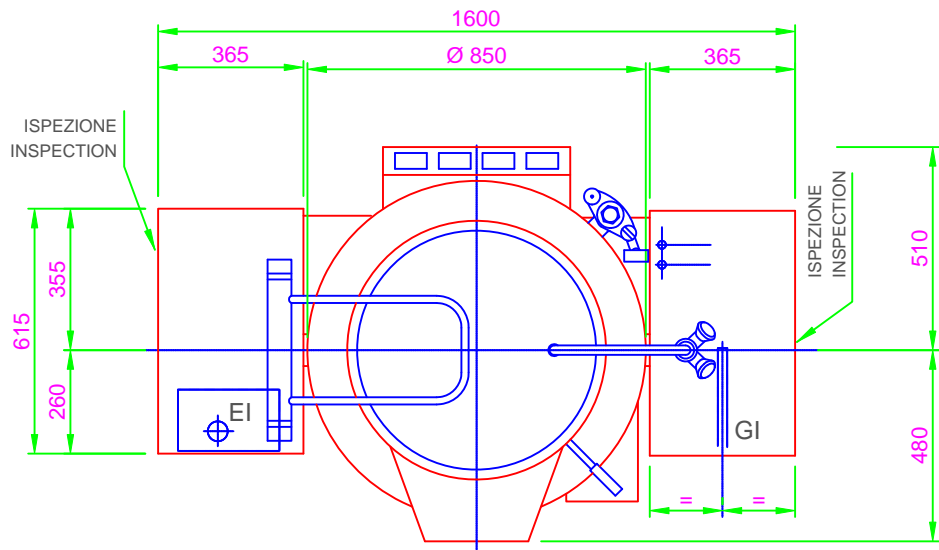

### ALLACCIAMENTI - BRANCHEMENTS - CONNECTIONS

HWI -	ACQUA CALDA EAU CHAUDE HOT WATER	1-2,5 bar	1/2" F
CWI -	ACQUA FREDDA EAU FROIDE COLD WATER	1-2,5 bar	1/2" F
GI -	ARRIVO GAS ENTREE GAZ GAS INLET	24 kW	1/2" M
EI -	ARRIVO CAVI ELETTRICI ENTREE CABLE ELECTRIQUE ELECTRIC CORD ENTRY	3N 380-415V 50-60Hz	0,37kW
DS -	DISTANZA DI SICUREZZA ESPACE DE SECURITE SAFETY DISTANCE		